

SERIE PRISMA

PRISMA15, PRISMA25, PRISMA35N Y PRISMA45N

BOMBA MULTITAPAS HORIZONTAL

SERIE PRISMA

PRISMA15, PRISMA25, PRISMA35N Y PRISMA45N

ESPECIFICACIONES

Bombas centrífugas multietapas horizontales para aplicaciones de bombeo de agua limpia donde se requiera una bomba robusta y compacta. Destaca por contar con tratamiento de cataforesis (proceso de pintado por inmersión) para evitar la oxidación y por su operación extremadamente silenciosa y su capacidad autoaspirante hasta 2 m.

APLICACIONES

- Suministro de agua a viviendas.
- Sistemas de riego.
- Sistemas hidroneumáticos.
- Sistemas de presión constante.

MATERIALES

- Camisa(tubo envolvente) en acero inoxidable 304
- Eje motor en acero inoxidable 420
- Impulsores en acero inoxidable 304
- Difusores fabricados en tecnopolímero Noryl® (PPO con Carga de fibra de vidrio)
- Cuerpo de aspiración e impulsión en hierro fundido
- Sello mecánico de Grafito/alúmina
- Carcasa del motor en aluminio

MOTOR

- Asíncrono, dos polos
- Protección IP 55
- Aislamiento clase F
- Servicio continuo

CARACTERÍSTICAS DE OPERACIÓN

- Temperatura del líquido: 4°C hasta 40°C
- Autoaspirante a 2 m.c.a

DESCRIPCIÓN DEL CÓDIGO

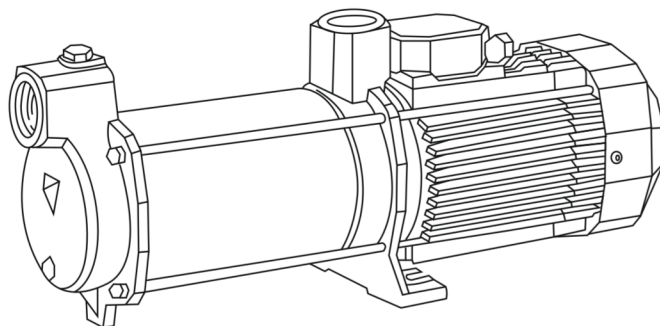
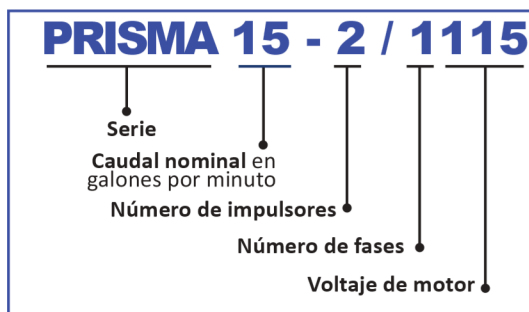

CURVAS DE OPERACIÓN PRISMA 15



TABLA DE ESPECIFICACIONES

BOMBAS CENTRÍFUGAS MULTIETAPAS HORIZONTALES MARCA ESPA Serie PRISMA

CÓDIGO	HP	KW	FASES X VOLTS	AMP.	SUCCIÓN X DESCARGA (pulgadas)	DMS*	PRESIÓN AL CIERRE (m/psi)	CARGA EN METROS (psi)					PESO (kg)
								10 (14.2)	20 (28.4)	30 (42.6)	40 (56.8)	50 (71)	
								GASTO (lpm)					
PRISMA15-2/1115	1/2	0.37	1 x 115	5.8	1" x 1"	1.25"	34/48	68	51	22		8.6	
PRISMA15-3/1115	3/4	0.55		8.5			50/71	75	63	49	32	9.2	
PRISMA15-3/1220			1 x 220	4.7									

Nota: Las bombas PRISMA trifásicas pueden ser conectadas a 220V o 440V según sea necesario, siguiendo el diagrama descrito en la caja de conexiones.

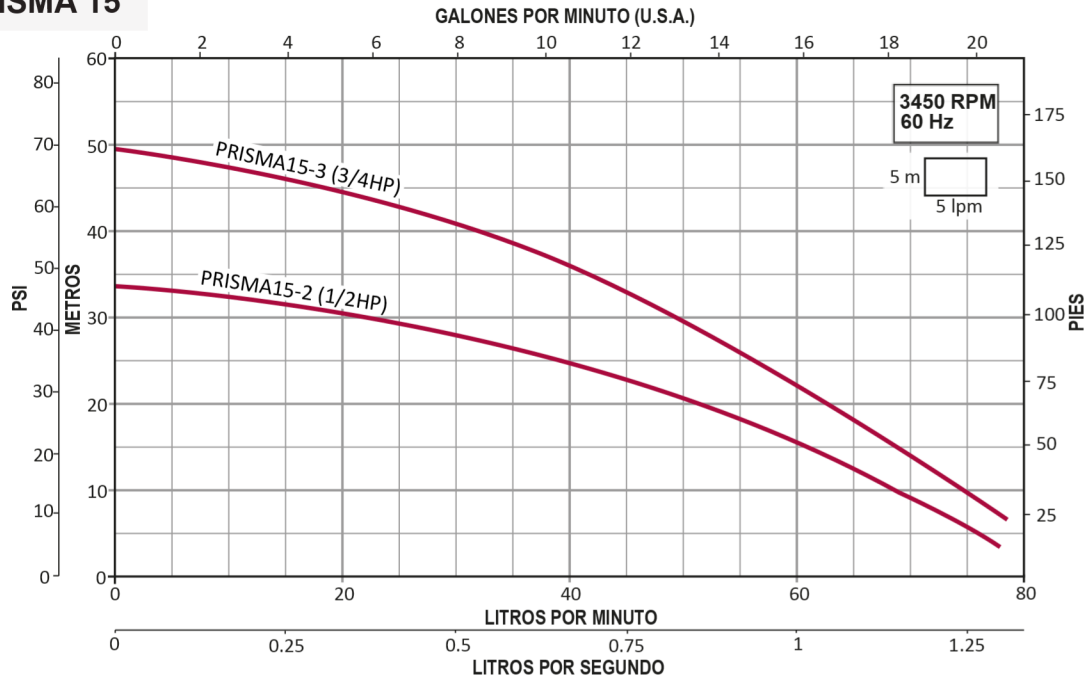
DIMENSIONES Y PESO

CÓDIGO	DIMENSIONES (mm)											Kg.
	A	B	C	D	E	F	G	H	I	J	K	
PRISMA15-2/1115	139	202	74	189	110	1"	1"	121	162	151	102	8.3
PRISMA15-3/1115	163	202	74	213	110	1"	1"	121	162	151	102	9.2
PRISMA15-3/1220	187	202	74	237	110	1"	1"	121	162	151	102	10

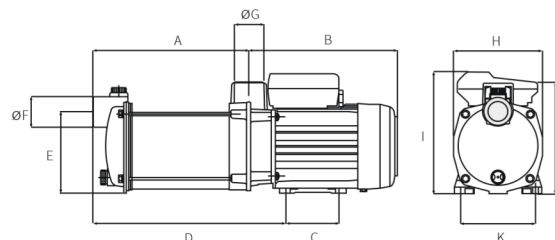

CURVAS DE OPERACIÓN

PRISMA 25



TABLA DE ESPECIFICACIONES

BOMBAS CENTRÍFUGAS MULTIETAPAS HORIZONTALES MARCA ESPA Serie PRISMA

CÓDIGO	HP	KW	FASES X VOLTS	AMP.	SUCCIÓN X DESCARGA (pulgadas)	DMS*	PRESIÓN AL CIERRE (m/psi)	CARGA EN METROS (psi)						PESO (kg)
								10 (14.2)	20 (28.4)	30 (42.6)	40 (56.8)	50 (71)	60 (85.2)	
								GASTO (lpm)						
PRISMA25-2/1115	1	0.75	1 x 115	11.5	1" x 1"	1.25"	34/48		108	55			14	
PRISMA25-2/1220			1 x 220	6										
PRISMA25-3/1115	1.5	1.1	1 x 115	16.5			50/71		112	82			18.5	
PRISMA25-3/1220			1 x 220	8.3										
PRISMA25-4/1220	2	1.5		12			66/93		114	92	65		21.2	
PRISMA25-4/3220			3x220/440	6.5/3.8								18.5		

DIMENSIONES Y PESO

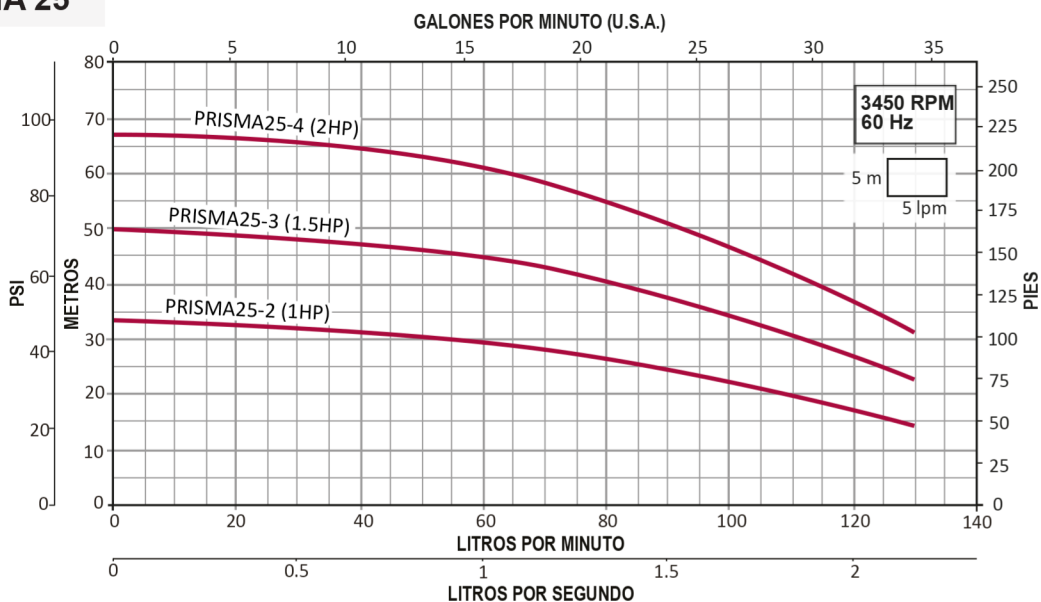
CÓDIGO	DIMENSIONES (mm)												PESO (Kg)
	A	B	C	D	E	F	G	H	I	J	K	L	
PRISMA25-2/1220	176	218	82	226	127	1"	1"	138	185	173	118	8	13.5
PRISMA25-2/1115													

CÓDIGO	DIMENSIONES (mm)												PESO (Kg)
	A	B	C	D	E	F	G	H	I	J	K		
PRISMA25-3/1115	202	286	142	1"	1"	225	154	212	192	138	8	17.2	
PRISMA25-3/1220													
PRISMA25-4/1220	229	286	142	1"	1"	225	154	212	192	138	10	20	
PRISMA25-4/3220													

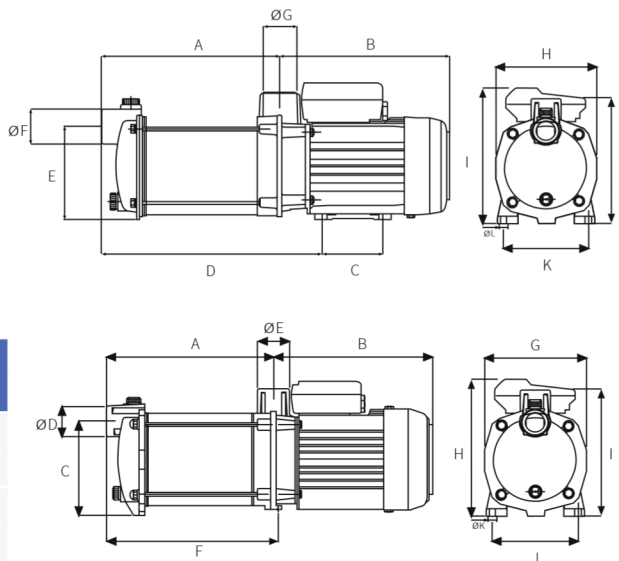

CURVAS DE OPERACIÓN PRISMA 35N



TABLA DE ESPECIFICACIONES

CÓDIGO	HP	KW	FASES X VOLTS	AMP.	SUCCIÓN X DESCARGA (pulgadas)	DMS*	PRESIÓN AL CIERRE (m/psi)	CARGA EN METROS (psi)						PESO (kg)		
								15 (21.3)	20 (28.4)	30 (42.6)	40 (56.8)	50 (71)	60 (85.2)			
								GASTO (lpm)								
PRISMA35N-2/1220	1.5	1.1	1x220	8.1	1.25"x1.25"	1.5"	42/59	198	175	128	48			19.7		
PRISMA35N-2/3224				5.2/2.9												
PRISMA35N-3/3224	2	1.5	3x220/440	7.3/4.2					64/90		203	175	144	107	50	22.4
PRISMA35N-4/3224	3	2.2		9/5.2					78/110		204	180	157	130	100	22.8

DIMENSIONES Y PESO

CÓDIGO	DIMENSIONES (mm)											Kg.
	A	B	C	D	E	F	G	H	I	J	K	
PRISMA35N-2/1220	176	281.5	147	1 1/4"	1 1/4"	162.8	158	212	207	120	12	18.1
PRISMA35N-2/3224	205	281.5	147	1 1/4"	1 1/4"	162.8	158	212	207	120	12	20.1
PRISMA35N-3/3224	233	281.5	147	1 1/4"	1 1/4"	187.3	158	212	207	120	12	23.1
PRISMA35N-4/3224	246.6	281.5	147	1 1/4"	1 1/4"	211.8	158	212	207	120	12	23.3

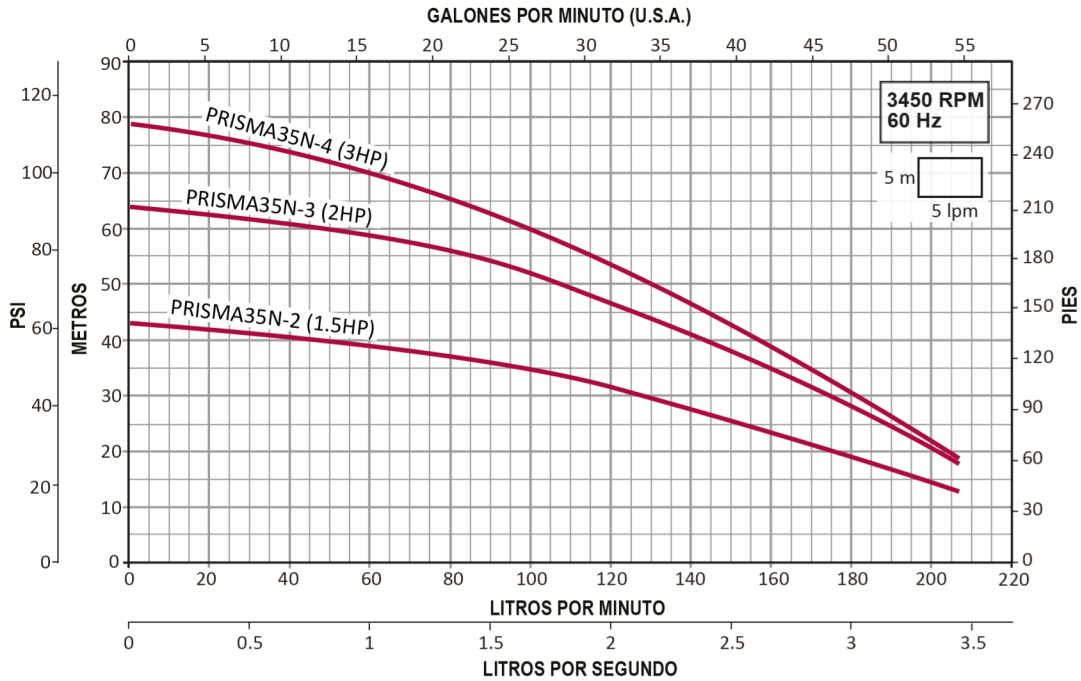
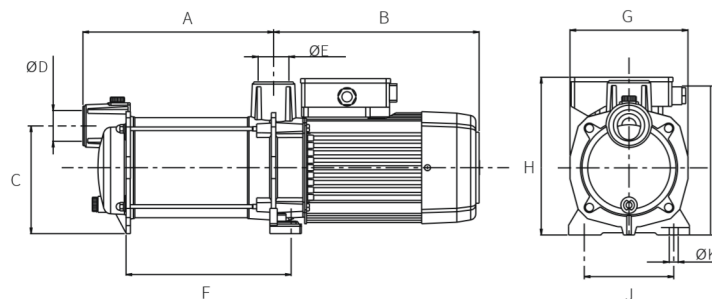

CURVAS DE OPERACIÓN

PRISMA 45N



TABLA DE ESPECIFICACIONES

CÓDIGO	HP	KW	FASES X VOLTS	AMP.	SUCCIÓN X DESCARGA (pulgadas)	DMS*	PRESIÓN AL CIERRE (m/psi)	CARGA EN METROS (psi)						PESO (kg)
								10 (14.2)	20 (28.4)	30 (42.6)	40 (56.8)	50 (71)	60 (85.2)	
								GASTO (lpm)						
PRISMA45N-2/1220	2	1.5	1 x 220	10.5	1.5" x 1.25"	2"	38/53	290	232	152				22.5
PRISMA45N-2/3224		1.5	3x220/440	6/3.5				20.1						
PRISMA45N-3/3224	3	2.2			8.6/5		55/78	311	273	228	180	100	22.9	

DIMENSIONES Y PESO

CÓDIGO	DIMENSIONES (mm)											Kg.
	A	B	C	D	E	F	G	H	I	J	K	
PRISMA45N-2/1220	186	297.5	147	1 1/2"	1 1/4"	150.2	161	218	207	140	17.5	22.2
PRISMA45N-2/3224	216.5	297.5	147	1 1/2"	1 1/4"	180.9	161	218	207	140	17.5	23.3
PRISMA45N-3/3224	247	297.5	147	1 1/2"	1 1/4"	211.6	161	218	207	140	17.5	24.9

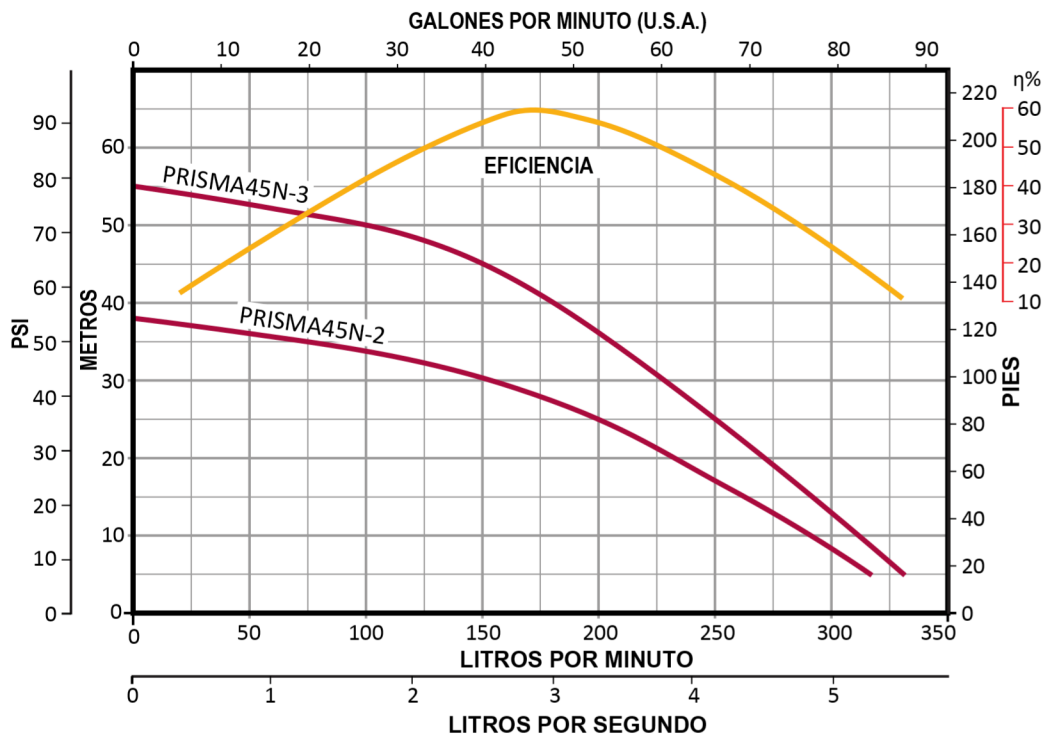
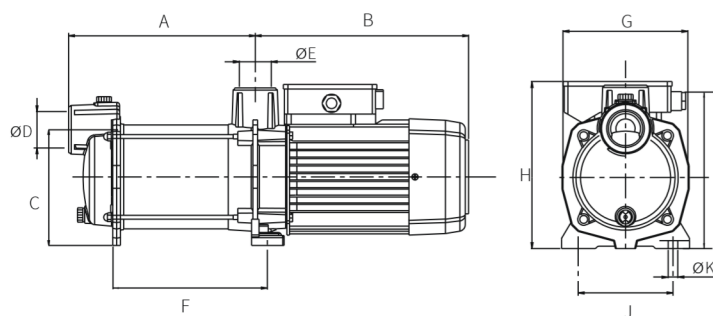



**BOMBA MULTIETAPAS
HORIZONTAL**

PRISMA

