

**DESCRIPTION:**

The AS-2 is a versatile on/off safety control suitable for use with a variety of electrical equipment. The AS-2 is for 240VAC equipment. Typical applications include bypass control of a time clock or on-off switching of other devices. Typical installations are illustrated below.

**INPUT / OUTPUT SERVICE RATINGS:**

240 V, 16 A, 2 Hp, 50/60 Hz, 2 wire plus ground. Minimum supply conductor rated 20 A, fuse or circuit breaker rated 20 A; Maximum Output Rating for Motor or Resistive Load: 240 V, 16 A, 60 Hz and 240 V, 12 FLA, 60 Hz.

**TYPICAL INSTALLATION:**

**AS-2 Standard Installation:**

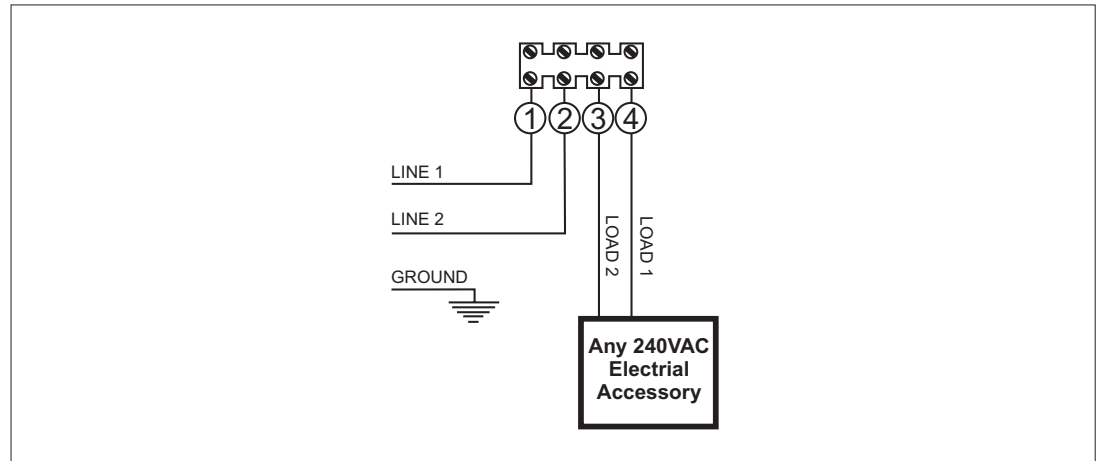

**AS-2 Time Clock Bypass:**

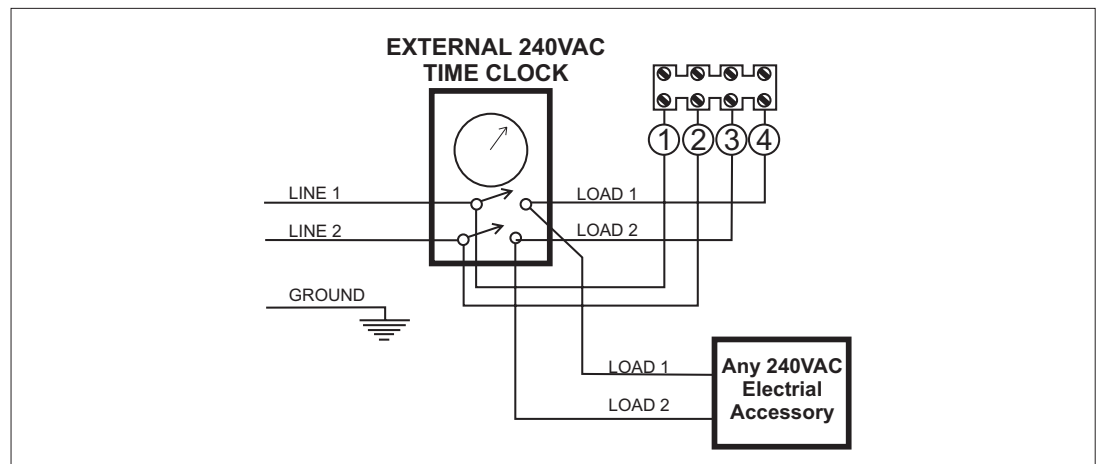

**NOTE:** Ground connections are not shown and vary with installation.

**CAUTION:** All connections shown in wiring diagram **MUST** be used. NEVER attempt to jumper, cross over, or bypass any connection. One wiring error will cause **PERMANENT INTERNAL DAMAGE**. Use one color of wire for Line 1 and Load 1. Use a different color of wire for Line 2 and Load 2. Be careful **NOT** to cross Line 1 or Load 1 with either Line 2 or Load 2. **DOUBLE-CHECK** all time clock wiring, as terminal designations vary with manufacturer.

**READ AND SAVE THESE INSTRUCTIONS**

# IMPORTANT SAFETY INSTRUCTIONS

## READ AND FOLLOW ALL INSTRUCTIONS

1. CAUTION: Risk of Electric shock. Install the electrical control box at least 5 feet (1.52 m) from inside wall of the pool, spa or hot tub.
2. Use only non-conductive tubing to any air actuator.
3. The electrical supply for this product must include a suitable rated switch or circuit breaker to open all ungrounded supply conductors to comply with section 422-20 of the National electric code, ANSI/NFPA 70-1987.
4. WARNING: To reduce the risk of injury, do not permit children to use this product unless they are closely supervised at all times.
5. For units for use in other than single family dwellings, a clearly labeled emergency switch shall be provided as part of the installation. The Switch shall be readily accessible to occupants and shall be installed at least 5 feet (1.52m) away, adjacent to, and within sight of the unit.
6. A pressure wire connector is provided on metallic enclosures to permit connections of a minimum No. 8 AWG solid copper bonding conductor between any metal equipment, metal enclosures of electrical equipment, metal water pipe, or conduit within 5 feet (1.5 m) of the unit as needed to comply with local requirements. Plastic enclosures are supplied with an internal equipment ground bar.
7. THIS CONTROL MUST BE FACTORY INSTALLED BY A LICENSED ELECTRICIAN ACCORDING TO STATE, NATIONAL, AND LOCAL ELECTRICAL CODE AND INSTRUCTIONS.
8. Use copper conductors only.
9. Install conduit down to provide drainage of compartment for electrical components.
10. A ground-fault circuit interrupter (GFCI) designated line is to be installed in accordance with National Electrical Code, Canadian Electrical Code and all local codes in effect at the time of installation. When unit is provided with GFCI, the GFCI must be tested monthly. To conduct the test, the unit must be operating. Push the test button. The unit should stop operating and the reset button should appear. Push the reset button. The unit should now operate normally. If the interrupter fails to operate in this manner, there is a ground flowing. Indicating the possibility of electrical shock. Disconnect the power unit. The fault has been corrected.

## READ AND SAVE THESE INSTRUCTIONS

## WARRANTY

Allied Innovations LLC warrants its products to be free from defects in workmanship and material under normal use and conditions for a period of one year from the date of original manufacture. Should repair be required by reason of any defect or malfunction during the warranty period, Allied Innovations LLC will repair, or at their discretion, replace this product without charge, subject to verification of the defect or malfunction. The repair is required after the expiration date of the warranty period, Allied Innovations LLC will repair this product and bill for any necessary replacement parts, shipping and handling.

This warranty is void if: 1) the unit is not installed per the instruction; 2) is connected to improper voltage; 3) is subjected to chemical corrosion; 4) is mechanically or electrically altered in any way; 5) is subjected to water or immersion; 6) contacts show evidence of short circuiting, or the unit has been visibly damaged by accident or misuse or which has been damaged by wind, rain, lighting, freezing or other cause; 7) upon which the serial number or manufacture date has been altered, effaced or removed. There is a charge for replacement parts if the defective unit is returned for any of the reasons listed above.

Allied Innovations LLC shall not be liable for any inconvenience, loss of time or incidental expenses incurred. Allied Innovations LLC shall not be liable for any labor charges associated with the removal or re-installation of any so-called defective products.

This is the only warranty expressed by Allied Innovations LLC. Warranties implied under state law, including any implied warranty of merchantability or fitness for a particular purpose, shall be limited to one year from the date of manufacture.

Allied Innovations LLC disclaims any liability for any incidental or consequential damages.

### Ship as follows:

1. Pack the unit in a well padded, heavy corrugated box.
2. Include name, return address and daytime phone number along with a short description of problem with control.
3. Mail the unit, prepaid, to the address listed below:  
**Technical Service Department  
Allied Innovations LLC  
7215 Bermuda Road  
Las Vegas, NV 89119-4304**
4. All repairs are warranted for a period of 90 days from date of repair.
5. Repairs will be held a maximum of 90 days. During this period, if there is no approval to proceed with repair within 60 days, the customer will be sent a letter of product status. After the 90 days, if there is no response, product is discarded.

Some states do not allow the exclusion or limitation of incidental or consequential damages, therefore the above limitations may not apply to you.

## ALLIED INNOVATIONS, LLC



*Manufacturing the Product Lines of Len Gordon*  
7215 Bermuda Rd Las Vegas NV 89119-4304  
Phone (702) 361-0600 Fax (702) 361-0613  
www.AlliedInnovations.com